

SERVICE & OPERATING MANUAL INSTRUCTION



**For models:
K20-550, K20-1800, K20-2500**

READ SAFETY RECOMMENDATIONS BEFORE OPERATING THIS TOOL

KRAIS Tube Expanders

Poland, 55-106 Zawonia, Czachowo 15
tel. +48 71 312 05 96, fax +48 71 387 03 32
<http://www.krais.com>



Safety Recommendations

For your safety and the safety of others, read and understand the safety recommendations and operating instructions before using this tool.



For additional information on eye and face protection, refer to Federal OSHA Regulations, 29 Code of federal regulations, Section 1910.133 Eye and Face Protection, and American National Standards Institute, ANSI A87.1, Occupational and Educational Eye and Face Protection Z87.1 is available from the American National Standards Institute, 11 West 42nd Street, New York, NY 10036.



Hearing protectors are required in high noise areas, 85 dBA or greater. The operation of tools and equipment in the area, reflective surfaces, process noises and non-resonant structures can substantially contribute to and increase the noise level in the area. Excessive air pressure above 90 psig or worn motor components can also increase sound level emitted by tool. Proper hearing conversation measures, including annual audiograms and training in the use and fit of hearing protection devices may be necessary.

Some individuals are susceptible to disorders of the hands and arms when exposed to task which involve highly repetitive motions or vibration. Those individuals predisposed to

vasculatory or circulation problems may be particularly susceptible. Cumulative trauma disorders such as Carpal Tunnel Syndrome and Tendonitis can be caused by repetitions, forceful exertions of the hands and arms. These disorders develop gradually over periods of weeks, months and years.

■ Tasks should be performed in such a manner that the wrists are maintained in a neutral position which is not flexed, hyperextended or turned side to side.

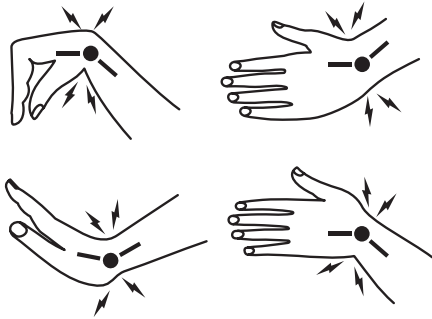

■ Stressful postures should be avoided and can be controlled through tool selection and work location. Any user suffering from prolonged symptoms of tingling, numbness, clumsiness or weakened grip, nocturnal pain in the hand or any other disorder of the shoulders, arms, wrists or fingers is advised to consult with a physician. If it is determined that the symptoms are job related or aggravated by movements and postures dictated by the job design it may be necessary for the employer to take steps to prevent further occurrences. These steps might include, but are not limited to repositioning the work piece or redesigning the work station, reassigning workers to other jobs, rotating jobs, altering work pace and/or changing the type of tools

Safety Recommendations

used so as to minimize stress on the operator. Some tasks may require more than one type of tool to obtain the optimum operator/tool/task relationship.

The following recommendations will help reduce or moderate the effects of repetitive work motions and/ or extended vibration exposure.

- Use a minimum hand grip force consistent with proper control and safe operation.
- Keep wrists as straight as possible.
- Keep body and hands warm and dry.
- Avoid anything that inhibits blood circulation
- Smoking Tobacco
- Cold Temperatures
- Certain Drugs
- Avoid highly repetitive movements of hands and wrists, and continuous vibration exposure.

Follow good machine shop practices. Rotating shafts and moving components can entangle and entrap, and can result in serious injuries. Never wear long hair, loose fitting clothes, gloves, ties or jewelry when working with or near the equipment.

Work gloves with vibration reducing liners and wrist supports are available from some manufacturers of industrial work gloves. Tool wraps and grips are also available from a number of different manufacturers. These gloves, wraps and wrist supports are designed to reduce and moderate the effects of extended vibration exposure and repetitive wrist trauma. Since they vary widely in design, material, thickness vibration reduction and wrist support qualities, it is recommended the glove manufacturer be consulted for items designed for your specific application. **WARNING!** Proper fit gloves is important. Improperly fitted gloves

may restrict blood flow to the fingers and can substantially reduce grip strength. A booklet, Assembly Tool Ergonomics, is available free of charge by writing the following address:

KRAIS Tube Expanders
Poland, 55-106 Zawonia, Czachowo 15

For more information on the safe use of portable air tools, see the latest edition of ANSI B186.1, Safety Code for Portable Air Tools, available from the American National Standards Institute, Inc., 11 West 42nd Street, New York, NY 10036.

This information is a compilation of general safety practices obtained from various sources available at the date of production. However, KRAIS does not represent that every acceptable safety practice is offered herein, or that abnormal or unusual circumstances may not warrant or require additional procedures. Your work may require additional specific safety procedures as required by your company.

WARNING LABELS

The warning labels found on these tools are an essential part of the product. Labels should not be removed. Labels should be checked periodically for legibility. Replace warning labels when missing or when the information can no longer be read. Replacement labels can be ordered as any part.

Safety Recommendations

The Manual K-20 is a trigger operated rolling control with an automatic, torque controlled reversal. It is designed for use with regulated, filtered and lubricated 90 psig air (measured at the tool inlet), but can be used at lower pressures to lower the minimum torque setting if required (with some loss of free speed). The operator pulls the trigger to start the tool (before engaging the expander mandrel in soft tubes to avoid "staking") and holds it until the entire rolling operation is completed. The tool expands to a preset torque, reverses automatically and backs out to release the mandrel. The tool stops and resets when the operator releases the trigger between tubes. If necessary, the tool can be started in reverse by unscrewing the clutch housing (32) three or four turns and pulling back gently on the tool before pulling the trigger.

KRAIS CLUTCH ADJUSTMENT

Remove clutch housing (32) (left hand threads) and spindle/clutch assembly from tool, taking care to avoid loss of push rod (52) or spring (51). Hold clutch driver (58) with a 3/8" wrench and turn the adjusting nut (39) with a 3/4" open end wrench (right hand thread). Compressing the spring increases the torque setting. Reinstall the spindle/clutch assembly and the clutch cover carefully to avoid damaging the push rod. For very light torque settings, the adjusting nut (39) can be locked to the spindle with a #8-32 x 3/16" nylon tipped set screw (not included).

CHANGING THE TORQUE REGULATING SPRING

Remove clutch housing (# 32) (left hand thread) and spindle/clutch assembly from

the tool. Remove the socket head cap screw (# 46) and the chuck assembly (35, 34, 33, 31, 30 & 29), wave washer (36), bearing (37), c-ring (38), lock nut (39), lock washer (40) and regulating spring (41 and install the desired regulating spring and reassemble parts in reverse order. Make sure that the wave washer (36) is centered on the bearing guard (35) (1/4" chuck) or chuck body (34) (3/8" chuck) before securing the chuck. With the 1/4" chuck, it is important to always keep the screw (46) tight to avoid excessive wear to the spindle (48) and the chuck body (34). Set and test tool for proper reversal before resuming operations - SEE CAUTION.



CAUTION

If the clutch is adjusted over the maximum power output of the tool, the clutch will not function and the tool will operate like a stall type tool. Also, if the tool is being operated at its upper torque limits, a drop in air pressure could cause the clutch not to function due to a loss of motor power and the tool will function like a stall type tool.

OPERATIONAL CHECK: grip tool securely and be prepared to counteract stall torque in case the clutch is improperly adjusted.

Air supply

The tool is designed to operate on 90 psig maximum air pressure. The air pressure should be checked at the tool's inlet when the tool is running. An automatic in-line filter-lubricator is required. This will sustain the tool with clean, lubricated air; keeping it in sustained operation; and increase tool life. For maximum performance, use a 1/4" I.D. mini-

Safety Recommendations

imum air hose up to 8 ft.in length. If additional length is required, a 3/8" I.D. or larger hose should be connected to the 1/4" hose (or use 3/8" I.D. hose or larger the full length).

The air hose should be cleared of accumulated dirt and moisture. Then pour one half (1/2) teaspoon of 10W oil into the tool's air inlet before connecting the hose to the tool. A new hose should be similarly lubricated before placing in service. The tool should be cycled several times to disperse the oil before rolling tubes.

LUBRICATION

The in-line lubricator should be regularly checked and kept filled with a good grade of 10W machine oil. Application of the tool should govern how frequently it is greased. It is recommended that the idler gears receive a generous amount of No. 2 Moly grease after every 40 hours of operation. The clutch housing (left hand threads) and the clutch/spindle/driver assembly must be removed and the grease applied through the hex in the spider.

Service instructions

DISASSEMBLY

Clamp the handle (70) in a soft jawed vise and unscrew (left hand threads) the clutch housing (32) and remove the shaft/clutch assembly (48, 58 & 57). Pull out the push rod (52) and spring (51). Unscrew the gear train (59) from the handle (70) assembly. The motor (60) and valve assembly (1 thru 6) can now be removed from the handle (70). See the following paragraphs for disassembly instructions for the various sub-assemblies.

HANDLE MAINTENANCE

Unscrew the air inlet busing (80) and remove the air inlet screen (77), spring (76) and throttle valve (75). The air inlet screen should be washed in solvent and blown out in reverse of normal air flow. Replace the screen if clogged or torn. Inspect the throttle valve seal (75) and replace the valve if necessary. Inspect the "O" rings (78 & 79) and replace if necessary. If replacement of the trigger (71) or throttle pin (72) becomes necessary, check that the spring pin (73) will clear the back of the trigger slot before installing the pin. If there is interference, grind off enough of the throttle pin (72) so that the trigger will clear. If this is not done, the tool will not shut off when the trigger is released. Before putting the throttle valve (75) back into the tool, push the throttle pin (72) all the way forward and make sure that the notch in the end of the throttle pin is vertical so that the throttle pin will engage the throttle valve properly after assembly.

CLUTCH DISASSEMBLY

Disassemble per instructions in CHANGING THE TORQUE REGULATING SPRING. Remove ring (57), clutch driver (58) and

washers (49 & 50). Drive out the 1/16"x 3/16" spring pin (55) and remove the washer (42), cam (43), six balls (47), trip (56), spring bushing (54), spring (53), Tru Arc (44) and clutch (45).

GEAR CASE ASSEMBLY

A. Single Reduction

The spider (14) should be pressed out of the rear of the gear case (13). Remove the retain-er ring (11) and press the bearing (12) out of the front of the gear case (13). If replacement of the idler gear pins (15) is necessary, they should be pressed out of the rear of the spider (14). See Figure 1 for replacement pin height.

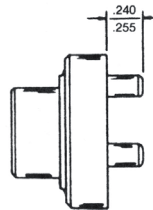
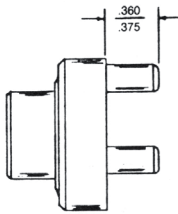

Fig. 1 - SINGLE REDUCTION SPIDER

B. Double Reduction

Both spiders (4 & 5) should be removed from the rear of the gear case (3). Remove the retainer ring (1) and press the bearing (2) out of the front of the gear case (3). If replacement of the idler gear pins (5 & 8) is necessary, they should be pressed out of the rear of the spiders (4 & 7). See Figure 2 for replacement pin height.

Service instructions



2nd Reduction Spider

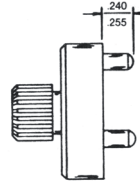

1st Reduction Spider

Fig. 2 - DOUBLE REDUCTION SPIDERS

MOTOR DISASSEMBLY

Slip the front bearing plate (20) and bearing (19) off the front of the rotor (22) and remove the cylinder (25) and four (4) rotor blades (24). Set the rear bearing plate 27) on the vise jaws with the rotor (22) hanging down. Use a 7/32" punch to drive the rotor (22) out of the rear rotor bearing (28).

REASSEMBLY IN GENERAL

All parts should be washed in a solvent and inspected for damage or wear. Particular attention should be given to all bearings, gears, gear pins and rotor blades as failure of these parts could cause damage to more expensive parts. Rotor blades should be replaced if they measure less than 3/16" on either end. Inspect and replace any "O" rings or seals that show signs of wear or deterioration. All gears, gear pins and open bearings should receive a generous amount of No. 2 Moly grease during reassembly. When assembling the gear case to the back head, the case should be torqued to 300/325 in. lbs. (33.9/36.7 Nm). Do not overtighten, as it can distort the valve assembly and cause the valve to stick. Reassembly of all of the various

sub-assemblies is in the reverse order of disassembly; however, the following paragraphs list some of the more important reassembly procedures.

CLUTCH ASSEMBLY

During the reassembly of the clutch assembly, all parts should receive a thin coating of a mixture of 10W machine oil and No. 2 Moly grease. The clutch (45), Tru Arc (44), spring (53), spring bushing (54), trip (56), balls (47), cam (43) and washer (42) must be in position on the clutch shaft (48) before installing the spring pin (55). Install the spring pin (55) so it is below the surface at both ends. The installation of the balls (47) can be simplified by filling the ball slots in the shaft (48) with grease if desired.

MOTOR ASSEMBLY

Install the rear rotor bearing (28) into the rear bearing plate. Press the bearing plate assembly (press on the bearing's inner race) onto the rear rotor shaft until there is approximately .001" clearance between the rear bearing plate and the rotor. Install the cylinder (25) with the slotted end toward the front bearing plate.

Service instructions

If a new rotor or complete motor assembly is to be installed, first install with RC609 Loctite, a push rod guide (61) - with the countersunk end in first, and the other end flush with the end of the rotor.

VALVE ASSEMBLY

Install valve sleeve (66) with Loctite RC609. The deepest notch (5/32" deep) in the sleeve must be flush with the valve insert (64) at the end adjacent to the motor package and the 1/16" diameter hole must be centered in the slot. Allow Loctite to cure per instructions on Loctite container. CLEAN sleeve thoroughly before installing the valve spool (67). The spool must move freely with the valve washer installed. Orient spool stop (62) as shown, and install pin (65) flush with the inside of the spool stop.

PUSH ROD

It is essential that the push rod be straight and that the ends be uniformly rounded and free

from burrs, or erratic operation can result. The length of the push rod (52) determines the location of the valve spool when the tool is running forward and has been sized to be used without trimming in most cases. When installing a replacement push rod - before screwing on the clutch cover, make sure that the two washers (49 & 50) are in place and that the end of the push rod does not touch the end of the trip (56) when the spindle assembly is held tightly in position. If the rod must be shortened, grind uniformly off the VALVE END of the rod just enough to allow the trip to reset without interference.

SAFETY CHECK

After repair or replacement of parts, servicing or prolonged storage, the tool should be tested to verify that the automatic torque reversal device is functioning properly. SEE CAUTION on page 5!

Gear train sub-assemblies

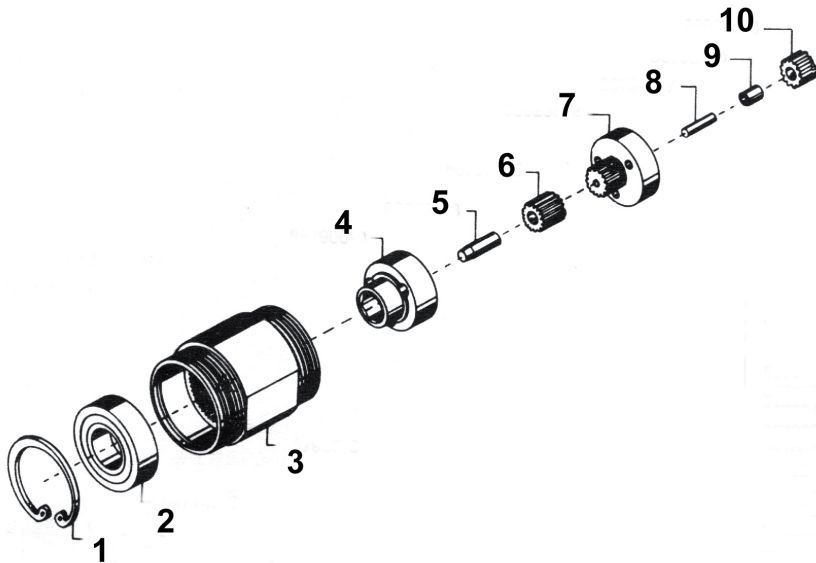

PARTS LIST For Manual K-20 Gear Train			
ITEM	PART	DESCRIPTION	QUANTITY
	KK-861719	Gear Train Sub-Assembly	1
1	KK-2976879	TruArc Ring	1
2	KK-847147	Spider Bearing	1
3	KK-867907	Gear Case (45T)	1
4	KK-867906	2nd Reduction Gear Spider - Incl 832128	1
5	KK-832128	2nd Reduction Gear Pin	3
6	KK-867904	2nd Reduction Gear (15T)	3
7	KK-869259	1st Reduction Spider - Incl 867922	1
8	KK-867922	1st Reduction Gear Pin	3
9	KK-867921	1st Reduction Gear Bearing	3
10	KK-869258	1st Reduction Gear (17T) - Incl 867921	3

Gear train sub-assemblies

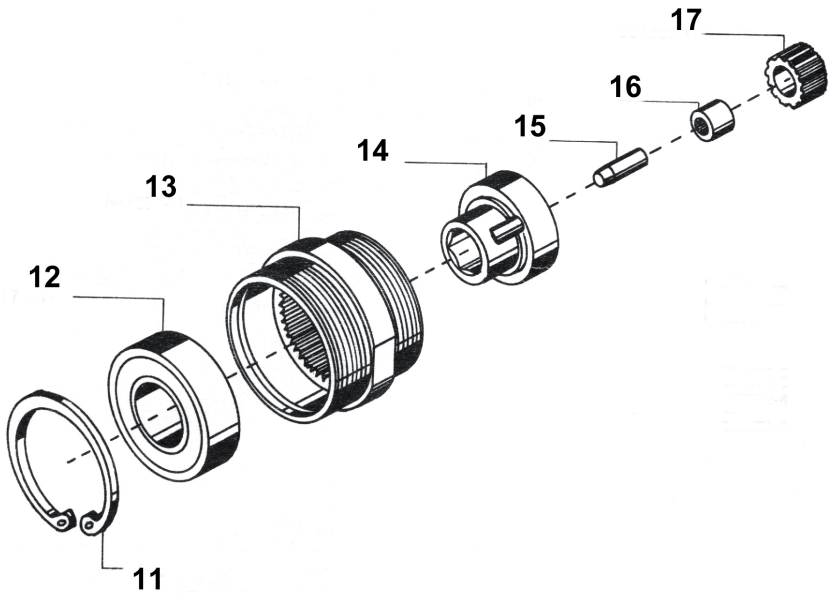

PARTS LIST For K20-1800 and K20-2500 Gear Train Sub-Assembly

ITEM	PART	DESCRIPTION	QUANTITY	
			1800 rpm	2500 rpm
	KK-861573	Gear Train Sub-Assembly (1800 RPM)	1	0
	KK-861680	Gear Train Sub-Assembly (2500 RPM)	0	1
11	KK-2976879	TruArc Ring	1	1
12	KK-847147	Spider Bearing	1	1
13	KK-867871	Gear Case	1	1
14	KK-867872	Gear Spider - Incl 687922 (1800 r.p.m.)	1	0
14	KK-869182	Gear Spider - Incl 687922 (2500 r.p.m.)	0	1
15	KK-867922	1st Reduction Gear Pin	3	3
16	KK-867921	1st Reduction Gear Bearing	3	3
17	KK-867866	Idler Gear (18T) - (Incl 867921)	3	0
17	KK-869181	Idler Gear (16T) - (Incl 867921)	0	3

Motor sub-assemblies

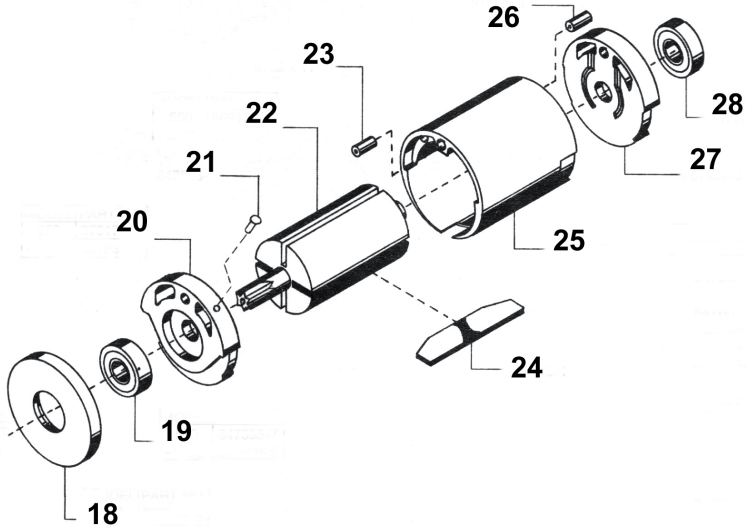

PARTS LIST For K20-550 and K20-1800 Motor Sub-Assembly

ITEM	PART	DESCRIPTION	QUANTITY	
			550/2500 RPM	1800 RPM
	KK-8405339	Motor Sub-Assembly (550 & 2500 RPM)	1	0
	KK-8405338	Motor Sub-Assembly (1800 RPM)	0	1
18	KK-869180	Spacer	1	0
18	KK-867873	Spacer	0	1
19	KK-847095	Front Rotor Bearing	1	0
19	KK-847609	Front Rotor Bearing	0	1
20	KK-879179	Front Bearing Plate	1	0
20	KK-867935	Front Bearing Plate	0	1
21	KK-847603	Pin	1	1
22	KK-869178	Rotor	1	0
22	KK-867885	Rotor	0	1
23	KK-8010357	Pin (3/32" x 7/16")	1	1
24	KK-863738	Rotor Blade	4	4
25	KK-867936	Cylinder	1	1
26	KK-8010338	Pin (3/32" x 1")	1	1
27	KK-867937	Rear Bearing Plate	1	1
28	KK-847609	Rear Rotor Bearing	1	1
NS	KK-8567145	Rod Guide (Not Shown)	1	1

PARTS LIST FOR MODEL K20					
ITEM	PART	DESCRIPTION	QUANTITY FOR MODEL		
			K20-550	K20-1800	K20-2500
29	KK-8503400	Tru Arc Ring	1	0	0
29	KK-2247980	Tru Arc Ring	0	1	1
30	KK-8565930	Chuck Sleeve	1	0	0
30	KK-8565900	Chuck Sleeve	0	1	1
31	KK-8501000	Spring	1	0	0
31	KK-8565910	Spring	0	1	1
32	KK-8567196	Clutch Housing	1	1	1
33	KK-3219000	Steel Ball	1	1	1
34	KK-8567200	Chuck Body	1	0	0
34	KK-8566853	Chuck Body	0	1	1
35	KK-8567181	Bearing Guard	1	1	1
36	KK-8567180	Wave Washer	1	1	1
37	KK-844772	Ball Bearing	1	1	1
38	KK-8010339	Tru Arc Ring	1	1	1
39	KK-3151200	Lock Nut	1	1	1
40	KK-3151000	Lock Washer	1	1	1
* 41	KK-3118800	Spring Plain 2-11	1	1	1
* 41	KK-3150300	Spring Yellow 6-30	1	1	0
* 41	KK-3150400	Spring Green 25-75	1	0	0
42	KK-3161300	Washer	1	1	1
43	KK-8566533	Cam	1	1	1
44	KK-3154500	Tru Arc Ring	1	1	1
45	KK-8566532	Clutch	1	1	1
46	KK-8010508	Soc. Hd. Cap Screw	1	0	0
46	KK-8010337	Soc. Hd. Cap Screw	0	1	1
47	KK-3151800	Ball	6	6	6
48	KK-8566867	Clutch Shaft	1	1	1
** 49	KK-8567157	Thrust Washer	1	1	1
** 50	KK-8010216	Red Nylon Washer 7/16" x .195" X .140"	1	1	1
51	KK-3150200	Valve Spring	1	1	1
52	KK-8567197	Push Rod	0	1	1
52	KK-8567198	Push Rod	1	0	0
53	KK-3160995	Spring	1	1	1
54	KK-3161007	Spring Bushing	1	1	1
55	KK-8010189	Spring Pin 1/16" x 3/8 "	1	1	1
56	KK-8566873	Trip	1	1	1

* Approximate range of spring in inch-pounds

** 8567157 bronze spacer is .010" thicker than 8010216 red nylon washer and is used to reduce spindle end play. Some assemblies use two (2) of the red nylon washers instead of using one of each.

*** THE VALVE SPOOL 8566859 AND VALVE BUSHING 8566860 ARE SOLD AS A MATCHED-HONED VALVE ASSEMBLY USING PART NUMBER 8405337

PARTS LIST FOR MODEL K20					
ITEM	PART	DESCRIPTION	QUANTITY FOR MODEL		
			K20-550	K20-1800	K20-2500
57	KK-2670100	Ring	1	1	1
58	KK-8566868	Clutch Driver	1	1	1
59	KK-861573	Gear Train 1800 rpm	0	1	0
59	KK-861719	Gear Train 550 rpm	1	0	0
60	KK-8405338	Motor Asbly 1800 rpm Includes 8010338	0	1	0
60	KK-8405339	Motor Asbly 550 rpm Includes 8010338	1	0	1
61	KK-8567145	Push Rod Guide	1	1	1
62	KK-8566863	Spool Stop	1	1	1
63	KK-8010338	Spring Pin 3/32" x 1"	1	1	1
64	KK-8566861	Valve Insert	1	1	1
65	KK-8010330	Spring Pin 1/16" x 1/4"	1	1	1
66	KK-8566860	Valve Bushing	1	1	0
67	KK-8566859	Valve Spool	1	1	0
68	KK-8010393	"O" Ring (012)	1	1	1
69	KK-8567144	Valve Washer	1	1	0
70	KK-8566838	Handle	1	1	1
71	KK-867054	Trigger	1	1	1
72	KK-867939	Throttle Pin	1	1	1
73	KK-8010135	Spring Pin 1/8" x 3/4"	1	1	1
74	KK-8567002	Muffler	1	1	1
75	KK-869350	Throttle Valve	1	1	1
76	KK-3132300	Spring	1	1	1
77	KK-412775	Inlet Screen	1	1	1
78	KK-3094500	"O" Ring (016)	1	1	1
79	KK-3110500	"O" Ring (111)	1	1	1
80	KK-867929	Air Inlet	1	1	1
PARTS INCLUDED BUT NOT SHOWN ON DRAWING					
NS	KK-8010134	Nylon Tipped Set Screw 8-32 x 3/16"	1	1	1
NS	KK-8010145	Hex Key 5/64"	1	1	1
NS	KK-8405340	Whip Hose 1/4" x 8 Ft.	1	1	1
OPTIONAL ITEMS AVAILABLE					
NS	KK-8405334	Chuck Complete 1/4" Sq.	1	1	1
NS	KK-8405403	Chuck Complete 3/8" Sq.	1	1	1

Parts drawing for Model K-20

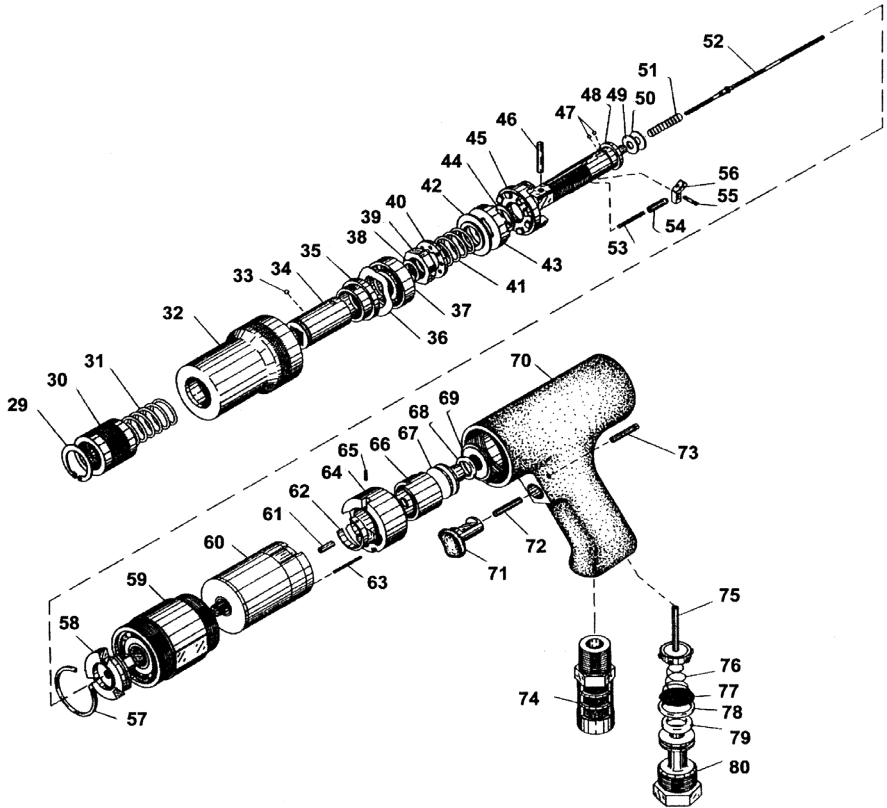

Warranty

KRAIS warrants products and parts sold by it, insofar as they are of its own manufacture, against defects of material and workmanship, under normal use and service in accordance with its written instructions, recommendations, and ratings for installation, operation, maintenance, and service of products, for a period of ONE YEAR FROM THE DATE OF INITIAL USE, BUT IN NO EVENT SHALL THE WARRANTY EXCEED 24 MONTHS FROM THE DATE OF DELIVERY TO DISTRIBUTOR. Proof of purchase with shipment date must be furnished by the user to validate the warranty. This warranty applies only to products manufactured by KRAIS and specifically excludes products manufactured by others. Products not manufactured by KRAIS are warranted only to the extent and in the manner warranted to KRAIS by the manufacturer and then only to the extent KRAIS is able to enforce such warranty. KRAIS warranty with respect to products manufactured by it is limited to the repair or replacement, as KRAIS may elect, of any defective part regarding which the distributor has given 5 days written notice from the discovery of such defect. Installation and transportation costs are not included. KRAIS shall have the option of requiring the return to it of the defective material, transportation prepaid, for inspection. No allowance will be made for repairs without KRAIS approval. KRAIS MAKES NO OTHER WARRANTY OF ANY KIND WHATSOEVER, EXPRESSED OR IMPLIED, AND HEREBY DISCLAIMS ALL WARRANTIES OF MERCHANTABILITY AND FITNESS FOR A PARTICULAR PURPOSE.



Przedsiębiorstwo Produkcyjno-Remontowe KRAIS

Poland, 55-106 Zawonia, Czachowo 15
tel. +48 71 312 05 96, fax +48 71 387 03 32

<http://www.krais.com>, email: expanders@krais.com