



# Tube Puller CP/CPS series

Pullers designed  
with cutting edge technology



**Tube Puller** ► MAIN FEATURES

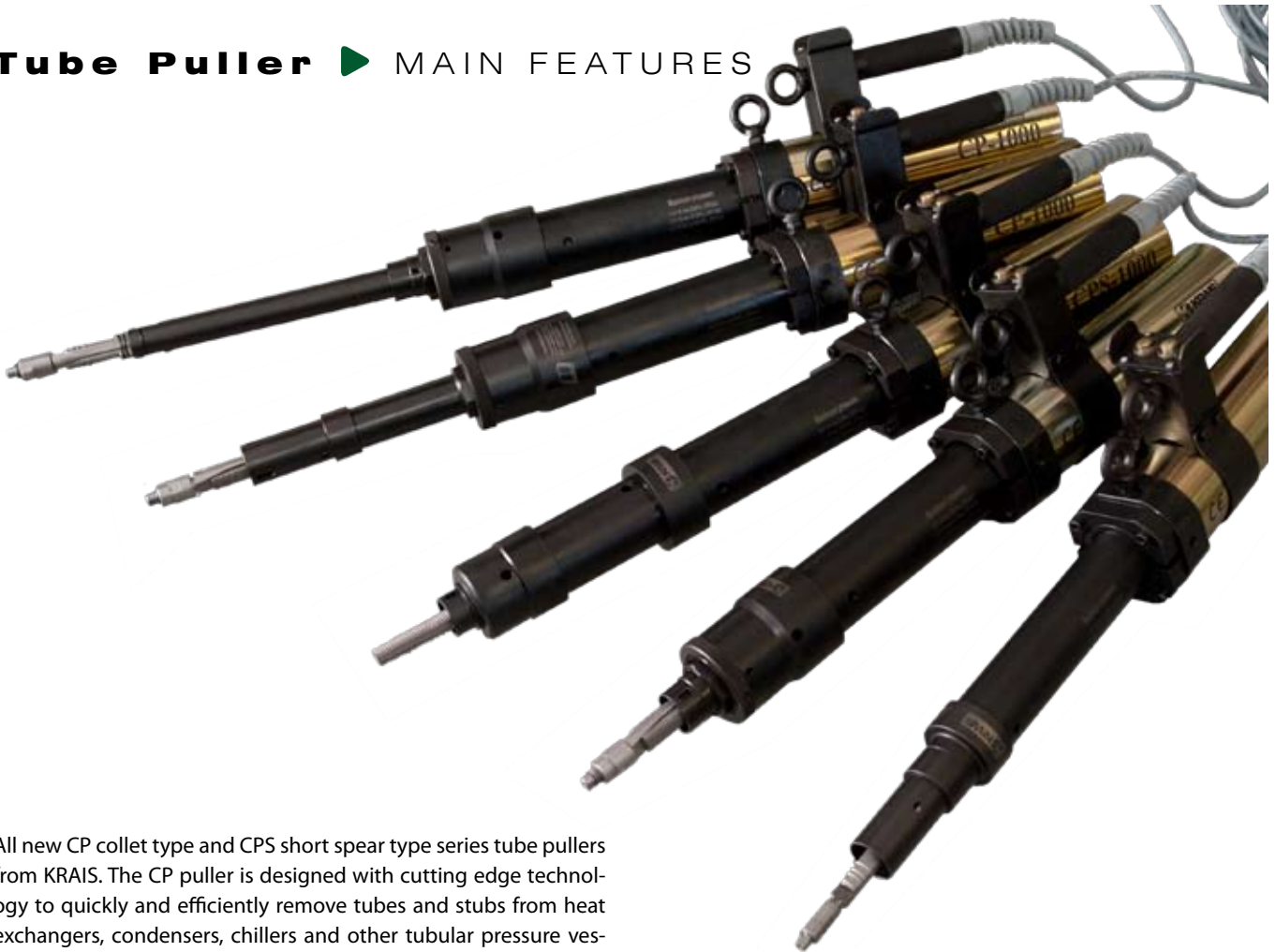

All new CP collet type and CPS short spear type series tube pullers from KRAIS. The CP puller is designed with cutting edge technology to quickly and efficiently remove tubes and stubs from heat exchangers, condensers, chillers and other tubular pressure vessels.

The state of art CP and CPS pullers deliver 15 tons of pulling force with a 6" stroke. The CP collet puller pulls tubes from 5/8" OD 1-1/2" OD from tube sheets up to 1-1/2" thickness. The CPS (short spear) collet puller pulls 1/2" to 1" OD tube from tube sheets up to 2-1/2" thickness including heavy gauge and all material type tubes as well as serrated tube sheet holes.

- Compact and lightweight design
- Rapid cylinder stroke for unmatched productivity and seamless operation
- Floating collet design for extended life
- Adjustable nose piece
- Many times faster than manual operation
- Ergonomically designed for ease of use

**CP-1000** | HOW IT WORKS

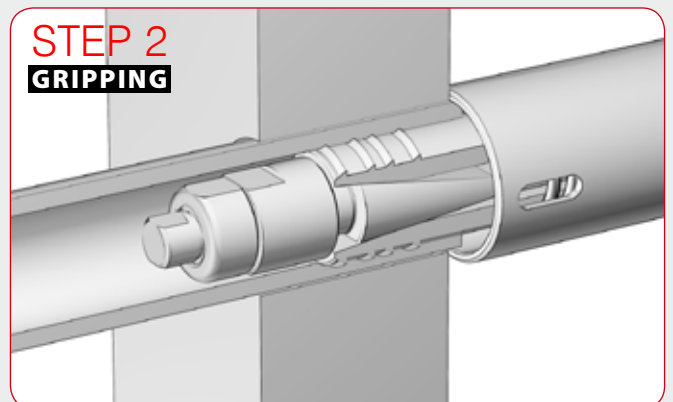
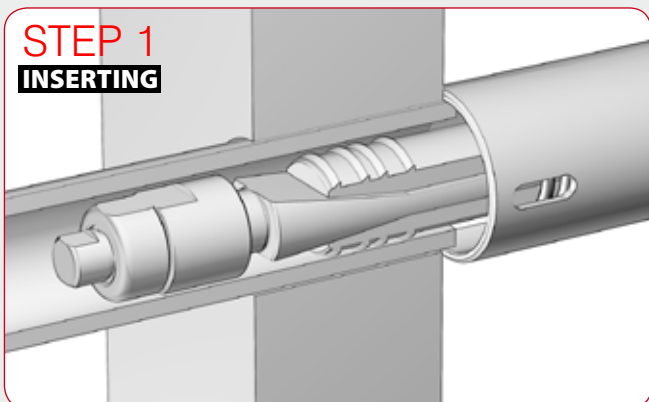

# Tube Puller ► MAIN FEATURES



Floating collet design for extended tool life



Adjustable handle for better tool balance with forward and backward trigger assures 100% control during the whole pulling cycle.

## CP-1000-FF Puller for FinFan



Model CP-1000 with the additional advantage of being able to remove stubs from the water-box of Fin Fan Coolers



This mock up shows how it works



Mock up of Fin Fan cooler 10" long water box and 1" tubes

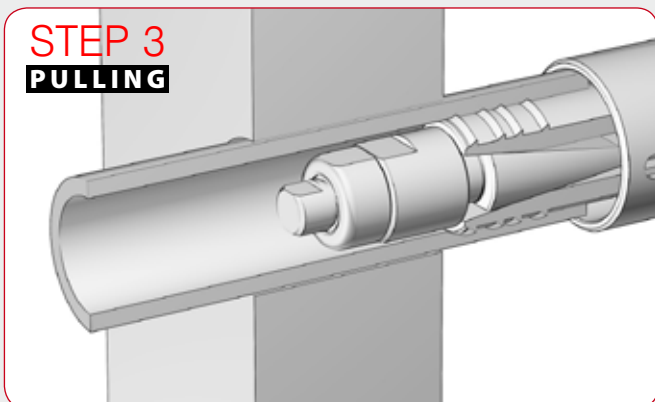

**STEP 3**  
**PULLING**

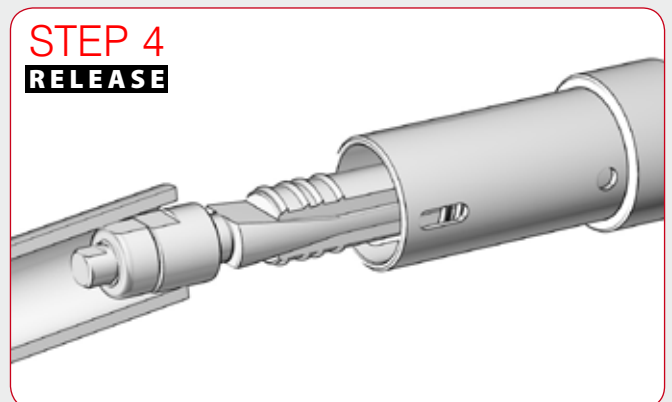

**STEP 4**  
**RELEASE**

# Tube Puller ▶ CP-1000



**CP-1000 | TECHNICAL DATA**

This unit has been designed to remove both ferrous and non-ferrous tubing from condensers, chillers and heat exchangers. Capacity from 5/8" to 1-1/2" O.D. gauge 16 to 24 (16 to 38 mm O.D. wall 0,5 to 1,6 mm) from tube sheet up to 2" (50 mm).

❗ The CP-1000 can be converted into our model CPS-1000 short spear type tube puller with the addition of our CPSCK-1000 conversion kit (Purchase separately. See picture enclosed on page 8). This addition allows the user to rapidly extract tubes or stubs of any gauge up to the units 15 Ton Capacity.

📺 You can download videos here:  
[www.krais.com/movies/CP1000-SS25X1pmac.wmv](http://www.krais.com/movies/CP1000-SS25X1pmac.wmv)  
[www.krais.com/movies/CP1000-CS-25X25pmac.wmv](http://www.krais.com/movies/CP1000-CS-25X25pmac.wmv)

**Specifications**

- Pulling force* ..... 15 T (150 kN)
- Pulling Stroke*..... 6 " (160 mm)
- Pulling speed*..... 0,7"/sec (17 mm/sec)
- Dimension*..... 3,38" x 32,67" (86 x 830 mm)
- Weight*..... 32 Lbs (14,5 kg)

**Consumables**

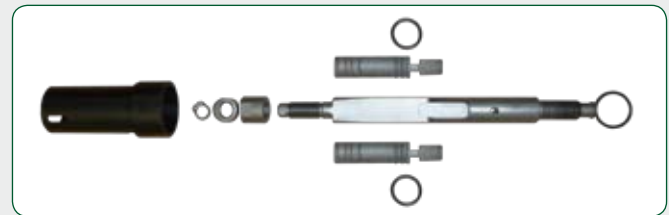

| TUBE O.D. | TUBE GAGE | GRIPPER SET       | MIN ENTER DIM AFTER EXP. | MAX ENTER DIM AFTER EXP. | DRAW MANDREL  | NOSE PIECE     | LOCK NUT     | ADJUST NUT   | JAW O'RING | C O'RING |
|-----------|-----------|-------------------|--------------------------|--------------------------|---------------|----------------|--------------|--------------|------------|----------|
| 5/8       | 16-17     | CP-1000-01-58-16  | 12,85 mm (0,506")        | 13,85 mm (0,545")        | CP-10L-03-58  | CP-10L-06A-58  | CP-10-LN-58  | CP-10-AN-58  | CP-2220    | CP-1724  |
|           | 18-19     | CP-1000-01-58-18  | 13,60 mm (0,535")        | 14,60 mm (0,574")        |               |                |              |              |            |          |
|           | 20-21     | CP-1000-01-58-20  | 14,30 mm (0,562")        | 15,30 mm (0,602")        |               |                |              |              |            |          |
|           | 22-23     | CP-1000-01-58-22  | 14,60 mm (0,576")        | 15,65 mm (0,616")        |               |                |              |              |            |          |
| 3/4       | 16-17     | CP-1000-01-34-16  | 16,05 mm (0,631")        | 17,05 mm (0,671")        | CP-10L-03-34  | CP-10L-06A-34  | CP-10-LN-34  | CP-10-AN-34  | CP-2220    | CP-1724  |
|           | 18-19     | CP-1000-01-34-18  | 16,90 mm (0,665")        | 17,90 mm (0,704")        |               |                |              |              |            |          |
|           | 20-21     | CP-1000-01-34-20  | 17,60 mm (0,692")        | 18,60 mm (0,732")        |               |                |              |              |            |          |
|           | 22-23     | CP-1000-01-34-22  | 17,95 mm (0,706")        | 18,95 mm (0,746")        |               |                |              |              |            |          |
| 7/8       | 16-17     | CP-1000-01-78-16  | 19,20 mm (0,755")        | 20,20 mm (0,795")        | CP-10L-03-78  | CP-10L-06A-78  | CP-10-LN-78  | CP-10-AN-78  | CP-2220    | CP-1724  |
|           | 18-19     | CP-1000-01-78-18  | 20,00 mm (0,787")        | 21,00 mm (0,826")        |               |                |              |              |            |          |
|           | 20-21     | CP-1000-01-78-20  | 20,70 mm (0,815")        | 21,70 mm (0,854")        |               |                |              |              |            |          |
|           | 22-23     | CP-1000-01-78-22  | 21,05 mm (0,828")        | 22,05 mm (0,868")        |               |                |              |              |            |          |
| 1         | 16-17     | CP-1000-01-1-16   | 22,40 mm (0,881")        | 23,40 mm (0,921")        | CP-10L-03-1   | CP-10L-06A-1   | CP-10-LN-1   | CP-10-AN-1   | CP-2220    | CP-1724  |
|           | 18-19     | CP-1000-01-1-18   | 23,20 mm (0,913")        | 24,20 mm (0,952")        |               |                |              |              |            |          |
|           | 20-21     | CP-1000-01-1-20   | 23,90 mm (0,941")        | 24,90 mm (0,980")        |               |                |              |              |            |          |
|           | 22-23     | CP-1000-01-1-22   | 24,70 mm (0,972")        | 25,70 mm (1,011")        |               |                |              |              |            |          |
| 1-1/4     | 16-17     | CP-1000-01-114-16 | 28,80 mm (1,133")        | 29,80 mm (1,173")        | CP-10L-03-114 | CP-10L-06A-114 | CP-10-LN-114 | CP-10-AN-114 | CP-2220    | CP-1724  |
|           | 18-19     | CP-1000-01-114-18 | 29,60 mm (1,165")        | 30,60 mm (1,204")        |               |                |              |              |            |          |
|           | 20-21     | CP-1000-01-114-20 | 30,35 mm (1,194")        | 31,35 mm (1,234")        |               |                |              |              |            |          |
|           | 22-23     | CP-1000-01-114-22 | 30,70 mm (1,208")        | 31,70 mm (1,248")        |               |                |              |              |            |          |
| 1-1/2     | 16-17     | CP-1000-01-112-16 | 35,20 mm (1,385")        | 36,20 mm (1,425")        | CP-10L-03-112 | CP-10L-06A-112 | CP-10-LN-112 | CP-10-AN-112 | CP-2220    | CP-1724  |
|           | 18-19     | CP-1000-01-112-18 | 36,00 mm (1,417")        | 37,00 mm (1,456")        |               |                |              |              |            |          |
|           | 20-21     | CP-1000-01-112-20 | 36,70 mm (1,444")        | 37,70 mm (1,484")        |               |                |              |              |            |          |
|           | 22-23     | CP-1000-01-112-22 | 37,05 mm (1,458")        | 38,05 mm (1,498")        |               |                |              |              |            |          |

NON STANDARD SIZES ON REQUEST

# Tube Puller ▶ CP-1000-S



## CP-1000-S | TECHNICAL DATA

This is a Shortened version of our model CP-1000. This unit has been designed to remove both ferrous and non-ferrous tubing from condensers, chillers and heat exchangers. Capacity from 5/8" to 1-1/2" O.D. gage 16 to 24 (16 to 38 mm O.D. wall 0,5 to 1,6 mm) from tube sheet up to 2" (50 mm)

🔧 The CP-1000 -S can be converted into our model CPS-1000 short spear type tube puller with the addition of our CPSCK-1000 conversion kit (Purchase separately. See picture enclosed on page 8). This addition allows the user to rapidly extract tubes or stubs of any gauge up to the units 15 Ton Capacity.

📺 You can download videos here:  
[www.krais.com/movies/CP1000-BRASSpmac.wmv](http://www.krais.com/movies/CP1000-BRASSpmac.wmv)  
[www.krais.com/movies/CP1000-CS-25X26pmac.wmv](http://www.krais.com/movies/CP1000-CS-25X26pmac.wmv)

### Specifications

- Pulling force* ..... 15 T (150 kN)
- Pulling Stroke*..... 6 " (160 mm)
- Pulling speed*..... 0,7"/sec (17 mm/sec)
- Dimension*..... 3,38" x 26,77" (86 x 680 mm)
- Weight*..... 30 Lbs (13,5 kg)

### Consumables

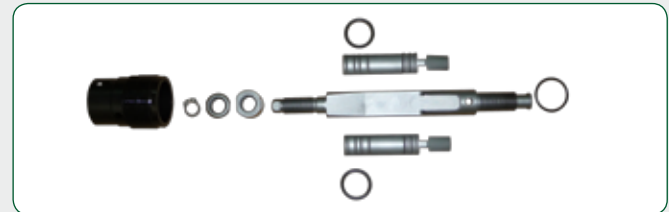

| TUBE O.D. | TUBE GAGE | GRIPPER SET       | MIN ENTER DIM AFTER EXP. | MAX ENTER DIM AFTER EXP. | DRAW MANDREL  | NOSE PIECE     | LOCK NUT     | ADJUST NUT   | JAW O'RING | C O'RING |
|-----------|-----------|-------------------|--------------------------|--------------------------|---------------|----------------|--------------|--------------|------------|----------|
| 5/8"      | 16-17     | CP-1000-01-58-16  | 12,85 mm (0,506")        | 13,85 mm (0,545")        | CP-10S-03-58  | CP-10S-06A-58  | CP-10-LN-58  | CP-10-AN-58  | CP-2220    | CP-1724  |
|           | 18-19     | CP-1000-01-58-18  | 13,60 mm (0,535")        | 14,60 mm (0,574")        |               |                |              |              |            |          |
|           | 20-21     | CP-1000-01-58-20  | 14,30 mm (0,562")        | 15,30 mm (0,602")        |               |                |              |              |            |          |
|           | 22-23     | CP-1000-01-58-22  | 14,60 mm (0,576")        | 15,65 mm (0,616")        |               |                |              |              |            |          |
| 3/4       | 16-17     | CP-1000-01-34-16  | 16,05 mm (0,631")        | 17,05 mm (0,671")        | CP-10S-03-34  | CP-10S-06A-34  | CP-10-LN-34  | CP-10-AN-34  | CP-2220    | CP-1724  |
|           | 18-19     | CP-1000-01-34-18  | 16,90 mm (0,665")        | 17,90 mm (0,704")        |               |                |              |              |            |          |
|           | 20-21     | CP-1000-01-34-20  | 17,60 mm (0,692")        | 18,60 mm (0,732")        |               |                |              |              |            |          |
|           | 22-23     | CP-1000-01-34-22  | 17,95 mm (0,706")        | 18,95 mm (0,746")        |               |                |              |              |            |          |
| 7/8       | 16-17     | CP-1000-01-78-16  | 19,20 mm (0,755")        | 20,20 mm (0,795")        | CP-10S-03-78  | CP-10S-06A-78  | CP-10-LN-78  | CP-10-AN-78  | CP-2220    | CP-1724  |
|           | 18-19     | CP-1000-01-78-18  | 20,00 mm (0,787")        | 21,00 mm (0,826")        |               |                |              |              |            |          |
|           | 20-21     | CP-1000-01-78-20  | 20,70 mm (0,815")        | 21,70 mm (0,854")        |               |                |              |              |            |          |
|           | 22-23     | CP-1000-01-78-22  | 21,05 mm (0,828")        | 22,05 mm (0,868")        |               |                |              |              |            |          |
| 1         | 16-17     | CP-1000-01-1-16   | 22,40 mm (0,881")        | 23,40 mm (0,921")        | CP-10S-03-1   | CP-10S-06A-1   | CP-10-LN-1   | CP-10-AN-1   | CP-2220    | CP-1724  |
|           | 18-19     | CP-1000-01-1-18   | 23,20 mm (0,913")        | 24,20 mm (0,952")        |               |                |              |              |            |          |
|           | 20-21     | CP-1000-01-1-20   | 23,90 mm (0,941")        | 24,90 mm (0,980")        |               |                |              |              |            |          |
|           | 22-23     | CP-1000-01-1-22   | 24,70 mm (0,972")        | 25,70 mm (1,011")        |               |                |              |              |            |          |
| 1-1/4     | 16-17     | CP-1000-01-114-16 | 28,80 mm (1,133")        | 29,80 mm (1,173")        | CP-10S-03-114 | CP-10S-06A-114 | CP-10-LN-114 | CP-10-AN-114 | CP-2220    | CP-1724  |
|           | 18-19     | CP-1000-01-114-18 | 29,60 mm (1,165")        | 30,60 mm (1,204")        |               |                |              |              |            |          |
|           | 20-21     | CP-1000-01-114-20 | 30,35 mm (1,194")        | 31,35 mm (1,234")        |               |                |              |              |            |          |
|           | 22-23     | CP-1000-01-114-22 | 30,70 mm (1,208")        | 31,70 mm (1,248")        |               |                |              |              |            |          |
| 1-1/2     | 16-17     | CP-1000-01-112-16 | 35,20 mm (1,385")        | 36,20 mm (1,425")        | CP-10S-03-112 | CP-10S-06A-112 | CP-10-LN-112 | CP-10-AN-112 | CP-2220    | CP-1724  |
|           | 18-19     | CP-1000-01-112-18 | 36,00 mm (1,417")        | 37,00 mm (1,456")        |               |                |              |              |            |          |
|           | 20-21     | CP-1000-01-112-20 | 36,70 mm (1,444")        | 37,70 mm (1,484")        |               |                |              |              |            |          |
|           | 22-23     | CP-1000-01-112-22 | 37,05 mm (1,458")        | 38,05 mm (1,498")        |               |                |              |              |            |          |

NON STANDARD SIZES ON REQUEST

# Tube Puller ▶ CP-1000-CC



## CP-1000-CC | TECHNICAL DATA

This is our lightweight unit, specifically designed for the condenser and chiller markets. An ideal tool for working within the waterbox of a surface condenser or within the channel head of a chiller, you can remove 4-6 tubes a minute quickly and effortlessly. Capacity from 5/8" to 1" O.D. gage 16 to 24 (16 to 25 mm O.D. wall 0,5 to 1,6 mm) from tube sheet up to 2" (50 mm).

 You can download video here:  
[www.krais.com/movies/CPC-1000-1.wmv](http://www.krais.com/movies/CPC-1000-1.wmv)

### Specifications

*Pulling force* ..... 15 T (150 kN)  
*Pulling Stroke*..... 6 " (160 mm)  
*Pulling speed*..... 0,7"/sec (17 mm/sec)  
*Dimension*..... 3,38" x 26,77" (86 x 680 mm)  
*Weight*..... 26,4 Lbs (12 kg)

### Consumables

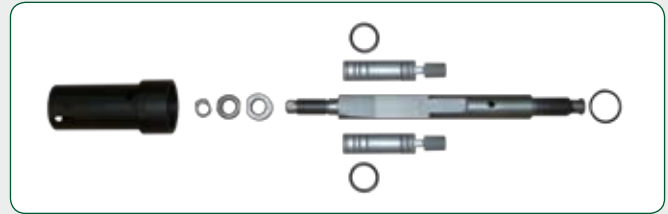

| TUBE O.D. | TUBE GAGE | GRIPPER SET      | MIN ENTER DIM AFTER EXP. | MAX ENTER DIM AFTER EXP. | DRAW MANDREL | NOSE PIECE    | LOCK NUT    | ADJUST NUT  | JAW O'RING | C O'RING |
|-----------|-----------|------------------|--------------------------|--------------------------|--------------|---------------|-------------|-------------|------------|----------|
| 5/8"      | 16-17     | CP-1000-01-58-16 | 12,85 mm (0,506")        | 13,85 mm (0,545")        | CP-10S-03-58 | CP-10L-06A-58 | CP-10-LN-58 | CP-10-AN-58 | CP-2220    | CP-1724  |
|           | 18-19     | CP-1000-01-58-18 | 13,60 mm (0,535")        | 14,60 mm (0,574")        |              |               |             |             |            |          |
|           | 20-21     | CP-1000-01-58-20 | 14,30 mm (0,562")        | 15,30 mm (0,602")        |              |               |             |             |            |          |
|           | 22-23     | CP-1000-01-58-22 | 14,60 mm (0,576")        | 15,65 mm (0,616")        |              |               |             |             |            |          |
| 3/4"      | 16-17     | CP-1000-01-34-16 | 16,05 mm (0,631")        | 17,05 mm (0,671")        | CP-10S-03-34 | CP-10L-06A-34 | CP-10-LN-34 | CP-10-AN-34 | CP-2220    | CP-1724  |
|           | 18-19     | CP-1000-01-34-18 | 16,90 mm (0,665")        | 17,90 mm (0,704")        |              |               |             |             |            |          |
|           | 20-21     | CP-1000-01-34-20 | 17,60 mm (0,692")        | 18,60 mm (0,732")        |              |               |             |             |            |          |
|           | 22-23     | CP-1000-01-34-22 | 17,95 mm (0,706")        | 18,95 mm (0,746")        |              |               |             |             |            |          |
| 7/8"      | 16-17     | CP-1000-01-78-16 | 19,20 mm (0,755")        | 20,20 mm (0,795")        | CP-10S-03-78 | CP-10L-06A-78 | CP-10-LN-78 | CP-10-AN-78 | CP-2220    | CP-1724  |
|           | 18-19     | CP-1000-01-78-18 | 20,00 mm (0,787")        | 21,00 mm (0,826")        |              |               |             |             |            |          |
|           | 20-21     | CP-1000-01-78-20 | 20,70 mm (0,815")        | 21,70 mm (0,854")        |              |               |             |             |            |          |
|           | 22-23     | CP-1000-01-78-22 | 21,05 mm (0,828")        | 22,05 mm (0,868")        |              |               |             |             |            |          |
| 1"        | 16-17     | CP-1000-01-1-16  | 22,40 mm (0,881")        | 23,40 mm (0,921")        | CP-10S-03-1  | CP-10L-06A-1  | CP-10-LN-1  | CP-10-AN-1  | CP-2220    | CP-1724  |
|           | 18-19     | CP-1000-01-1-18  | 23,20 mm (0,913")        | 24,20 mm (0,952")        |              |               |             |             |            |          |
|           | 20-21     | CP-1000-01-1-20  | 23,90 mm (0,941")        | 24,90 mm (0,980")        |              |               |             |             |            |          |
|           | 22-23     | CP-1000-01-1-22  | 24,70 mm (0,972")        | 25,70 mm (1,011")        |              |               |             |             |            |          |

NON STANDARD SIZES ON REQUEST

# Tube Puller ▶ CP-1000-FF



**CP-1000-FF | TECHNICAL DATA**

This unit has all the features of our Standard Model CP-1000 with the additional advantage of being able to remove stubs from the waterbox of Fin Fan Coolers as well as tubes/stubs close to the shell or pass partition plates within thermal exchange units. A standard waterbox depth of X is furnished with custom depths available upon request. Capacity from 5/8" to 1-1/2" O.D. gage 16 to 38 (16 to 38 mm O.D. wall 0,5 to 1,6 mm) from tube sheet up to 2" (50 mm)

**Specifications**

- Pulling force* ..... 15 T (150 kN)
- Pulling Stroke*..... 6 " (160 mm)
- Pulling speed*..... 0,7"/sec (17 mm/sec)
- Dimension*..... 3,38" x 36,61" (86 x 930 mm)
- Weight*..... 32 Lbs (14,5 kg)

🔧 We can supply the FF conversion kit to your specifications on all models of the CP-1000 and CP-1000-S.

📺 You can download video here:  
[www.krais.com/movies/CP-1000-FINFAN.wmv](http://www.krais.com/movies/CP-1000-FINFAN.wmv)

**Consumables**



| TUBE O.D. | TUBE GAGE | GRIPPER SET       | MIN ENTER DIM AFTER EXP. | MAX ENTER DIM AFTER EXP. | DRAW MANDREL  | NOSE PIECE     | LOCK NUT     | ADJUST NUT   | JAW O'RING | C O'RING | JAWS HOLDER   | MANDREL EXT. |
|-----------|-----------|-------------------|--------------------------|--------------------------|---------------|----------------|--------------|--------------|------------|----------|---------------|--------------|
| 5/8'      | 16-17     | CP-1000-01-58-16  | 12,85 mm (0,506")        | 13,85 mm (0,545")        | CP-10L-03-58  | CP-10S-06A-58  | CP-10-LN-58  | CP-10-AN-58  | CP-2220    | CP-1724  | CP-JH-58-10"  | CP-10-DM-EXT |
|           | 18-19     | CP-1000-01-58-18  | 13,60 mm (0,535")        | 14,60 mm (0,574")        |               |                |              |              |            |          |               |              |
|           | 20-21     | CP-1000-01-58-20  | 14,30 mm (0,562")        | 15,30 mm (0,602")        |               |                |              |              |            |          |               |              |
|           | 22-23     | CP-1000-01-58-22  | 14,60 mm (0,576")        | 15,65 mm (0,616")        |               |                |              |              |            |          |               |              |
| 3/4       | 16-17     | CP-1000-01-34-16  | 16,05 mm (0,631")        | 17,05 mm (0,671")        | CP-10L-03-34  | CP-10S-06A-34  | CP-10-LN-34  | CP-10-AN-34  | CP-2220    | CP-1724  | CP-JH-34-10"  | CP-10-DM-EXT |
|           | 18-19     | CP-1000-01-34-18  | 16,90 mm (0,665")        | 17,90 mm (0,704")        |               |                |              |              |            |          |               |              |
|           | 20-21     | CP-1000-01-34-20  | 17,60 mm (0,692")        | 18,60 mm (0,732")        |               |                |              |              |            |          |               |              |
|           | 22-23     | CP-1000-01-34-22  | 17,95 mm (0,706")        | 18,95 mm (0,746")        |               |                |              |              |            |          |               |              |
| 7/8       | 16-17     | CP-1000-01-78-16  | 19,20 mm (0,755")        | 20,20 mm (0,795")        | CP-10L-03-78  | CP-10S-06A-78  | CP-10-LN-78  | CP-10-AN-78  | CP-2220    | CP-1724  | CP-JH-78-10"  | CP-10-DM-EXT |
|           | 18-19     | CP-1000-01-78-18  | 20,00 mm (0,787")        | 21,00 mm (0,826")        |               |                |              |              |            |          |               |              |
|           | 20-21     | CP-1000-01-78-20  | 20,70 mm (0,815")        | 21,70 mm (0,854")        |               |                |              |              |            |          |               |              |
|           | 22-23     | CP-1000-01-78-22  | 21,05 mm (0,828")        | 22,05 mm (0,868")        |               |                |              |              |            |          |               |              |
| 1         | 16-17     | CP-1000-01-1-16   | 22,40 mm (0,881")        | 23,40 mm (0,921")        | CP-10L-03-1   | CP-10S-06A-1   | CP-10-LN-1   | CP-10-AN-1   | CP-2220    | CP-1724  | CP-JH-1-10"   | CP-10-DM-EXT |
|           | 18-19     | CP-1000-01-1-18   | 23,20 mm (0,913")        | 24,20 mm (0,952")        |               |                |              |              |            |          |               |              |
|           | 20-21     | CP-1000-01-1-20   | 23,90 mm (0,941")        | 24,90 mm (0,980")        |               |                |              |              |            |          |               |              |
|           | 22-23     | CP-1000-01-1-22   | 24,70 mm (0,972")        | 25,70 mm (1,011")        |               |                |              |              |            |          |               |              |
| 1-1/4     | 16-17     | CP-1000-01-114-16 | 28,80 mm (1,133")        | 29,80 mm (1,173")        | CP-10L-03-114 | CP-10S-06A-114 | CP-10-LN-114 | CP-10-AN-114 | CP-2220    | CP-1724  | CP-JH-58-114" | CP-10-DM-EXT |
|           | 18-19     | CP-1000-01-114-18 | 29,60 mm (1,165")        | 30,60 mm (1,204")        |               |                |              |              |            |          |               |              |
|           | 20-21     | CP-1000-01-114-20 | 30,35 mm (1,194")        | 31,35 mm (1,234")        |               |                |              |              |            |          |               |              |
|           | 22-23     | CP-1000-01-114-22 | 30,70 mm (1,208")        | 31,70 mm (1,248")        |               |                |              |              |            |          |               |              |
| 1-1/2     | 16-17     | CP-1000-01-112-16 | 35,20 mm (1,385")        | 36,20 mm (1,425")        | CP-10L-03-112 | CP-10S-06A-112 | CP-10-LN-112 | CP-10-AN-112 | CP-2220    | CP-1724  | CP-JH-58-114" | CP-10-DM-EXT |
|           | 18-19     | CP-1000-01-112-18 | 36,00 mm (1,417")        | 37,00 mm (1,456")        |               |                |              |              |            |          |               |              |
|           | 20-21     | CP-1000-01-112-20 | 36,70 mm (1,444")        | 37,70 mm (1,484")        |               |                |              |              |            |          |               |              |
|           | 22-23     | CP-1000-01-112-22 | 37,05 mm (1,458")        | 38,05 mm (1,498")        |               |                |              |              |            |          |               |              |

NON STANDARD SIZES ON REQUEST

# Tube Puller ► CPS-1000



## CPS-1000 | TECHNICAL DATA

Our short spear type puller has been designed to pull ferrous, non-ferrous and alloy tubing & stubs from heat exchangers, chillers, condensers and similar thermal exchange equipment. Capacity from 1/2" to 1" O.D. of any gauge up to the units 15 Ton Capacity. (12 to 25 mm O.D. any wall thickness up to the units 15T Capacity) from tube sheet up to 2,25" (57 mm)

Utilizing economical short spear technology, our patented extraction system, automatically grips and releases the spear at the end of its cycle.

 This system is simple and cost efficient to own & operate, due to the small amount of consumable required to extract a tube when compared to other pulling technologies.

 You can download video here:  
[www.krais.com/movies/CPS-1000pmac.wmv](http://www.krais.com/movies/CPS-1000pmac.wmv)

### Specifications

- Pulling force* ..... 15 T (150 kN)
- Pulling stroke* ..... 6 " (160 mm)
- Pulling speed* ..... 0,7"/sec (17 mm/sec)
- Dimensions* ..... 3,38" x 26,77" (86 x 680 mm)
- Weight* ..... 26,4 Lbs (12 kg)

### Consumables

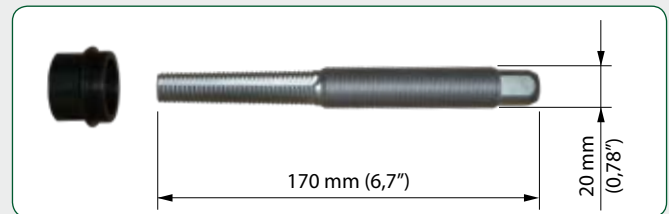

| TUBE O.D. | TUBE GAGE | SPEARS       | NOSE PIECE    |
|-----------|-----------|--------------|---------------|
| 5/8"      | 10-11     | CPS-58-10-11 | CPS-10-06A-34 |
|           | 12-13     | CPS-58-12-13 |               |
|           | 14-15     | CPS-58-14-15 |               |
|           | 16-17     | CPS-58-16-17 |               |
| 3/4"      | 10-11     | CPS-34-10-11 | CPS-10-06A-34 |
|           | 12-13     | CPS-34-12-13 |               |
|           | 14-15     | CPS-34-14-15 |               |
|           | 16-17     | CPS-34-16-17 |               |
| 7/8"      | 10-11     | CPS-78-10-11 | CPS-10-06A-78 |
|           | 12-13     | CPS-78-12-13 |               |
|           | 14-15     | CPS-78-14-15 |               |
|           | 16-17     | CPS-78-16-17 |               |
| 1"        | 10-11     | CPS-1-10-11  | CPS-10-06A-1  |
|           | 12-13     | CPS-1-12-13  |               |
|           | 14-15     | CPS-1-14-15  |               |
|           | 16-17     | CPS-1-16-17  |               |

## CPSCK-1000 Conversion kit

Designed for: **CP-1000** | **SP-1000-S**



CPSCK-1000 conversion kit is design to convert the CP-1000 and SP-1000-S into the short spear type tube puller allowing the user to rapidly extract ferrous, non-ferrous and alloy tubing & stubs from heat exchangers, chillers, condensers and similar thermal exchange equipment.

Capacity from 1/2" to 1" O.D. of any gauge up to the units 15 Ton Capacity (12 to 25 mm O.D. any wall thickness up to the units 15T Capacity) from tube sheet up to 2,25" (57 mm).

Utilizing economical short spear technology, our patented extraction system, automatically grips and releases the spear at the end of its cycle.

## Tube Puller ► CPS-2000



### CPS-2000 | TECHNICAL DATA

Our short spear type puller has been designed to pull ferrous, non-ferrous and alloy tubing & stubs from heat exchangers, chillers, condensers and similar thermal exchange equipment. Capacity from 1" to 2,25" O.D. of any gauge up to the units 30 Ton Capacity (25 to 57 mm O.D. any wall thickness up to the units 30T Capacity) from tube sheet up to 2,25" (57 mm) Utilizing economical short spear technology, our patented extraction system, automatically grips and releases the spear at the end of its cycle.

! This system is simple and cost efficient to own & operate, due to the small amount of consumable required to extract a tube when compared to other pulling technologies.

! You can download video here:  
[www.krais.com/movies/CPS-2000pmac.wmv](http://www.krais.com/movies/CPS-2000pmac.wmv)

### Specifications

*Pulling force* .....30T (300 kN)  
*Pulling Stroke*.....6" (160 mm)  
*Pulling speed*.....0,7"/sec (17 mm/sec)  
*Dimension*.....4,33" x 30,31" (110 x 770 mm)  
*Weight*.....68,2 Lbs (31 kg)

### Consumables

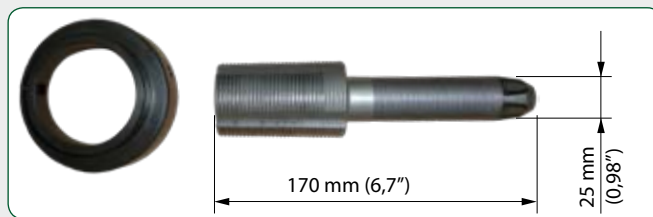

## PE-544 Hydraulic pump

Our Hydraulic Pumps have been designed to exacting standards to provide the maximum productivity from a lightweight pump, specifically designed for tough tube pulling Applications. Standard features include: two speed pump for high performance; light weight and portable; safe cage as standard; 10 Ft. remote pendant; 2-1/2 Gallon (9,5 liter) metal reservoir, large pressure gauge.

### Specifications

*Model number*.....PE-554  
*RPM*.....12 000  
*Max Pressure Output*.....10 000 psi / 690 Bar  
*Amp Draw for 10 000 psi / 690 Bar (230V)*.....25 Amps

### Oil delivery

|                 |                            |              |            |
|-----------------|----------------------------|--------------|------------|
| 100 psi.....    | 678 inch <sup>3</sup> /min | 6,9 Bar..... | 11,3 L/min |
| 700 psi.....    | 426 inch <sup>3</sup> /min | 48 Bar.....  | 7,1 L/min  |
| 5 000 psi.....  | 72 inch <sup>3</sup> /min  | 350 Bar..... | 1,2 L/min  |
| 10 000 psi..... | 54 inch <sup>3</sup> /min  | 690 Bar..... | 0,9 L/min  |

## MiniCut ► Main features

We highly recommend our new MiniCut series tube cutting machines.



MiniCut-600-LM is recommended to use for the condenser, chillers and other vassals with nonferrous tubes. The machine can cut 1" O.D. ga 16 brass tube in just a few seconds. This machines is equipped with lever feed.

 You can download video here:  
[www.krais.com/movies/MC-600-lever20x15.wmv](http://www.krais.com/movies/MC-600-lever20x15.wmv)

|                    | MINICUT-600-LM          |
|--------------------|-------------------------|
| Free speed         | 600 rpm                 |
| Torque             | 24 Nm                   |
| Pneumatic motor    | 1,3 Hp                  |
| Air consumption    | 1,3 m <sup>3</sup> /min |
| Air preasure       | 6,2 bar                 |
| Tube Capacity O.D. | 1"                      |
| Material           | brass, copper           |
| Weight             | 5,5 kg                  |



MiniCut-100-SM is recommended for stainless still and carbon steel tubes up to 1-1/4" O.D. with heavy wall gage 10 and up, and is equipped with star wheel feed for more feeding power.

 You can download video here:  
[www.krais.com/movies/minicut.wmv](http://www.krais.com/movies/minicut.wmv)

|                    | MINICUT-100-SM          |
|--------------------|-------------------------|
| Free speed         | 100 rpm                 |
| Torque             | 140 Nm                  |
| Pneumatic motor    | 1,3 Hp                  |
| Air consumption    | 1,3 m <sup>3</sup> /min |
| Air preasure       | 6,2 bar                 |
| Tube Capacity O.D. | 1-1/4"                  |
| Material           | any                     |
| Weight             | 5,5 kg                  |

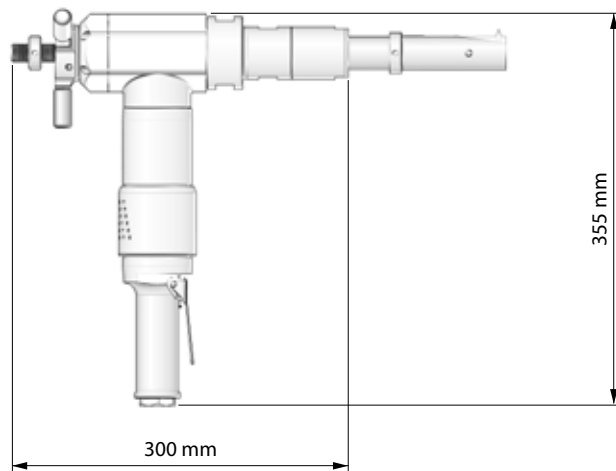

► **TUBE TRAKTOR**

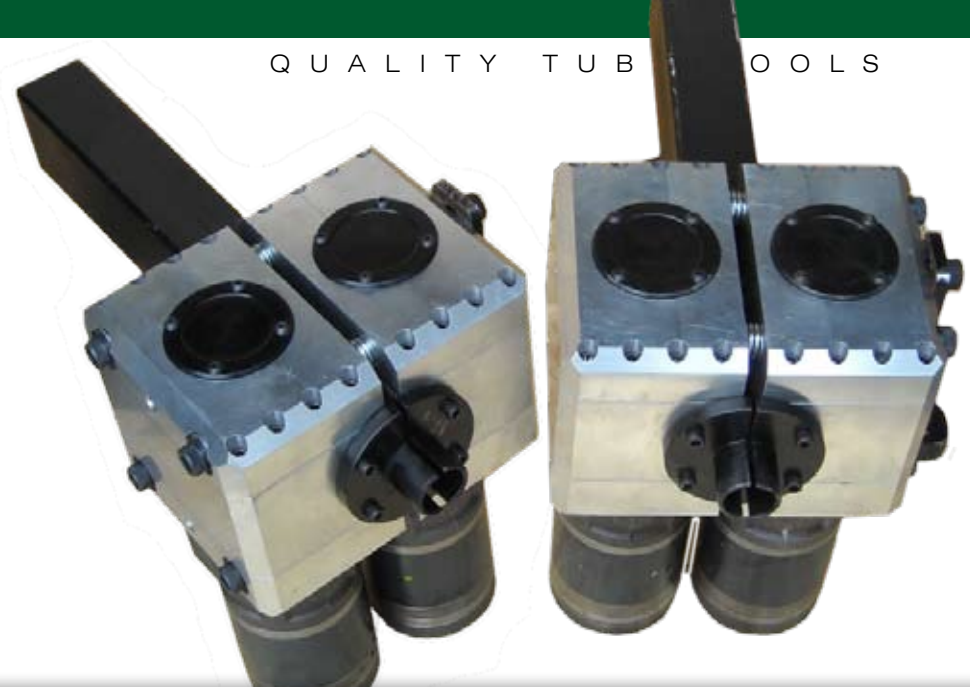

**CPS-2000** | TECHNICAL DATA



The Bite-Me Tube Traktor represent the latest evolution in high speed tube extracting equipment. Designed for use in conjunction with the Kraiss CP-1000 this compact powerful machine will enable the operator to extract and flatten tubes from condensers at speeds between 10 and 70 metres per minute once the expansion joint has been broken. Originally designed to remove and flatten non ferrous tubes from 5/8" to 1 1/4" OD the Tube Traktor can be used to extract ferrous tubes from 5/8" to 1 1/2" OD using radius shaped rolls to sized to fit each tube. Made from the highest quality materials this reliable dependant machine incorporates, highest quality hydraulic motors, solid 1 piece pulling rolls machined from tool steel and hardened for extended life, body components machined from marine grade aluminium for high strength, fully sealed bearings for hundreds of hours trouble free operation, and incorporates a built in lifting eye and handle.



The Tube Tracktors versatility is enhanced by the fact that it can run from almost any low pressure high flow hydraulic pump. The Tractors ideal operating pressure is 137 bar (2000 psi) with flows between 20lpm (5.0gpm US) to 100lpm (25.4gpm US) depending on the desired pulling speed. It is preferred that the pump have a pressure compensating bi-directional proportional flow control fitted for safe, accurate and efficient use of the pump and the Tube Traktor. However proportional flow control is not essential for flows up to 50lpm. The pump will also require forward and reverse flow as occasionally the Tube Traktor will need to be reversed. This will require a 3 position (Forward / Neutral / Reverse) joystick mounted to the Tube Traktor for ease of operation.



You can download video here:  
[http://www.krais.com/\\_plik/CPTT2.wmv](http://www.krais.com/_plik/CPTT2.wmv)



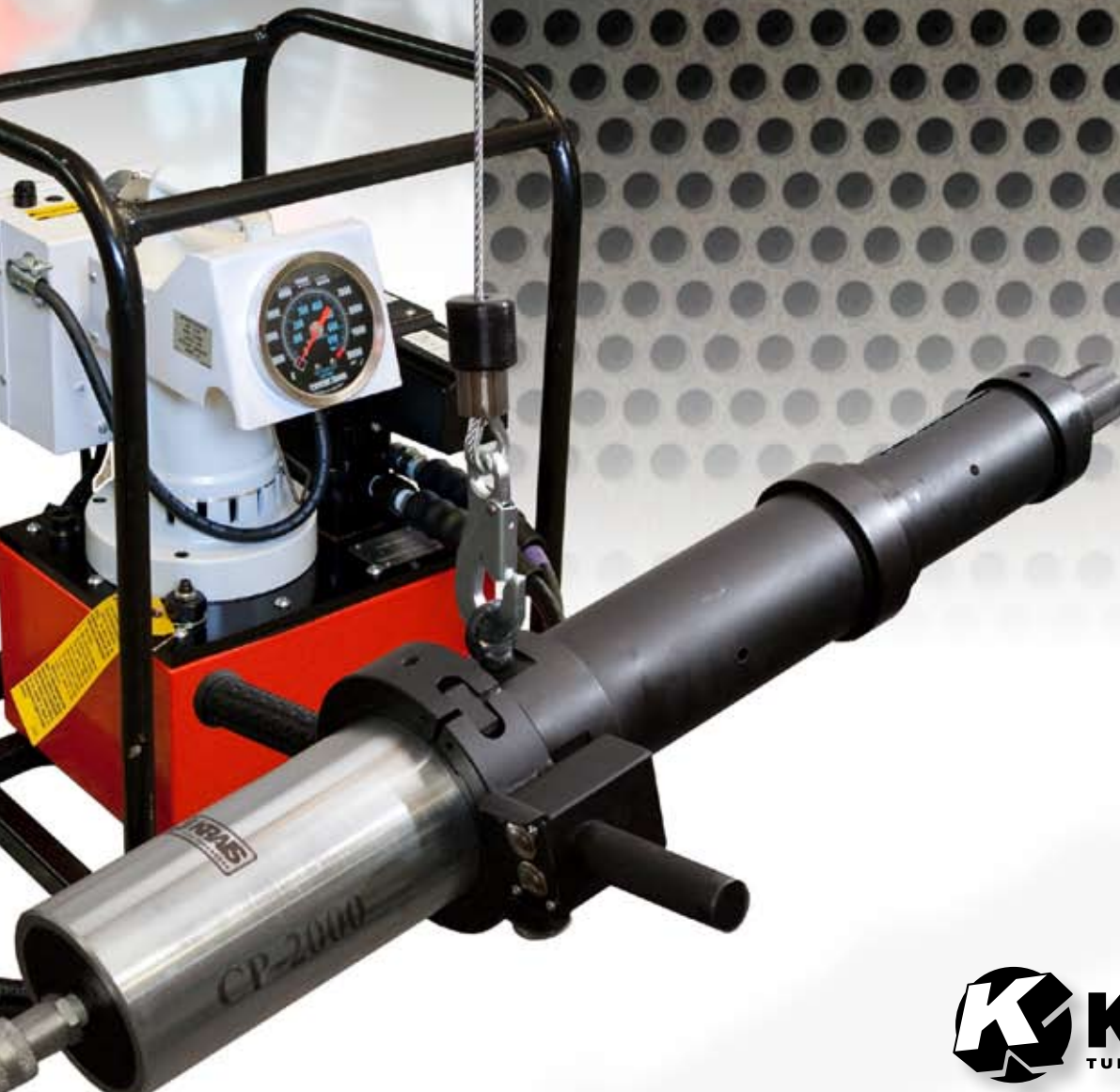

**KRAIS Tube Expanders**

Poland, 55-106 Zawonia  
Czachowo 15

tel. +48 71 312 05 96

fax +48 71 387 03 32

**<http://www.krais.com>**

email: [export@krais.com](mailto:export@krais.com)