

# MiniMill 100

The MiniMill 100 is a rugged, fast, portable weld end preparation lathe designed for tube and pipe, including stainless and other high chromium materials. Our standard machine comes complete to cover 20 - 74 mm i.d (0.787" - 2.913") with 88 mm cutting head.





Fitted with our optional multi feed system, the Mini Mill is easily changed from it's star wheel configuration to a ratchet drive for fast and accurate preps on water wall panels.

	APPLICATION RANGE	STD. LOCKING RANGE	FREE SPEED	POWER	TORQUE
<b>MiniMill100</b>	20 – 107 mm	20 – 74 mm	100 Rpm	1,3 Hp	140 Nm
	0,787 – 4,213 "	0,787 – 2,913 "			105 Ft.Lbs

**Recommended to** Tube facing ■ Tube bevelling ■ Weld removal

<b>Air use:</b>	55 cfm	1,3 m <sup>3</sup> /min	<b>Body width:</b>	2,32"	59 mm	<b>Body height:</b>	13,1"	335 mm	<b>Body weight:</b>	11,4 Lbs	5,2 kg
-----------------	--------	-------------------------	--------------------	-------	-------	---------------------	-------	--------	---------------------	----------	--------

## CUTTER HEADS

-  **OPTIONAL**  
60 mm | 2,36"
-  **STANDARD**  
88 mm | 3,46"
-  **OPTIONAL**  
106 mm | 4,17"

## LEVER FEED LM



Heavy duty feed handle ideal for heavy wall tube and pipe bevelling. Also well suited for strength and seal weld removal applications.

## MULTI FEED MM



Practical and easy to use multi feed system with Star Wheel and build in ratchet mechanism and handle.

**MINI SHAFT**



System with 3 interchangeable guide shafts 12.5, 13.6 & 15.5 mm. Complete jaw set to cover 12.5 to 23 mm (0.492" to 0.905") inside diameter.  
**JAWS FOR MINISHAFT, PAGE 41**

**SHAFT 20**



Shaft with jaw sets to cover 20 to 74 mm (0.787" to 2.914") inside diameter.  
**JAWS FOR SHAFT 20, PAGE 40**

**SHAFT 22**



Shaft with increased cross sectional diameter within the jaw retaining section. Enhances machining rigidity.  
**JAWS FOR SHAFT 22, PAGE 40**

**TFMH**



Tube facing milling head created for facing any type of material tubes. Utilizes 6% cobalt inserts.  
**TABLE FOR TFMH, PAGE 37**

**OBMH**



Custom, precisely designed head. Dedicated for the outside beveling of both tube and pipe. Sized per tube or pipe diameter and angle of required weld bevel. Heads are precisely engineered so the inserts cannot damage the shaft or locking jaws.  
**TABLE FOR OBMH, PAGE 37**

**STWRMH**



Custom designed head dedicated for strength weld removal. Heads are sized per tube diameter and are precisely engineered so the inserts cannot damage the shaft or locking jaws. Simple, error free set up, make these heads very advantageous.  
**TABLE FOR STWRMH, PAGE 36**

**SWROTC**



Seal weld removal head over tube circumference prior to re weld the damage joint without removing the tube.  
**TABLE FOR SWROTC, PAGE 38**

**MRBMH**



Seal weld removal head over tube circumference prior to re weld the damage joint without removing the tube.  
**TABLE FOR MRBMH, PAGE 39**

**FINFAN SEAL WELD REMOVAL ATTACHMENT**

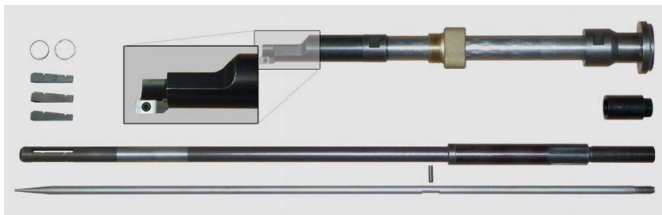

Simply the best solution for seal weld removal from air coolers. Adjustable length locking shaft and support bushing that fits into the plug thread, making this tool the best available on the market today. A cycle time of approximately 1 min from tube to tube can be expected.

**SPEED REDUCER**



Optional speed reducer can be used for seal and strength weld removal applications including, duplex, super duplex and other hard to machine alloys.  
**SPEED REDUCER, PAGE 4**

**PNEUMATIC LOCK**



This optional pneumatic lock decreases the cycle time between end preps up to 400% and is ideal for fabricating shops.  
**CLAMPING SYSTEM, PAGE <?>**

# MiniMill 100ESM

The MiniMill is a rugged, fast, portable weld end preparation lathe for tube & pipe including stainless and other high chromium alloys. Standard machine comes complete to cover 20 to 74 mm ID (0.787" to 2.910") with 88 mm cutting head. Electric motor is interchangeable with our pneumatic version and can be purchased separately.



 **ELECTRIC DRIVEN**





⚡ 110V or 220V motor produce fast and accurate weld preps.

	APPLICATION RANGE	STD. LOCKING RANGE	FREE SPEED	POWER	TORQUE
<b>MiniMill100ESM</b>	20 – 107 mm	20 – 74 mm	115 Rpm	1,1 W	366 Nm
	0,787 – 4,213 "	0,787 – 2,913 "			280 Ft.Lbs

**Recommended to**      **Tube facing ■ Tube bevelling ■ Weld removal**

<b>Power:</b>	230 V	<b>Body width:</b>	2,32"    59 mm	<b>Body height:</b>	18,5"    470 mm	<b>Body weight:</b>	15,0 Lbs    6,8 kg
---------------	-------	--------------------	----------------	---------------------	-----------------	---------------------	--------------------

## CUTTER HEADS

-  **OPTIONAL**  
60 mm | 2,36"
-  **STANDARD**  
88 mm | 3,46"
-  **OPTIONAL**  
106 mm | 4,17"

## LEVER FEED LM



Heavy duty feed handle ideal for heavy wall tube and pipe bevelling. Also well suited for strength and seal weld removal applications.

## MULTI FEED MM



Practical and easy to use multi feed system with Star Wheel and build in ratchet mechanism and handle.

**SHAFT 20**



Shaft with jaw sets to cover 20 to 74 mm (0.787" to 2.914") inside diameter.

JAWS FOR SHAFT 20, PAGE 40

**SHAFT 22**



Shaft with increased cross sectional diameter within the jaw retaining section. Enhances machining rigidity.

JAWS FOR SHAFT 22, PAGE 40

**OBMH**



Custom, precisely designed head. Dedicated for the outside beveling of both tube and pipe. Sized per tube or pipe diameter and angle of required weld bevel. Heads are precisely engineered so the inserts cannot damage the shaft or locking jaws.

TABLE FOR OBMH, PAGE 37

**STWRMH**



Custom designed head dedicated for strength weld removal. Heads are sized per tube diameter and are precisely engineered so the inserts cannot damage the shaft or locking jaws. Simple, error free set up, make these heads very advantageous.

TABLE FOR STWRMH, PAGE 36

**TFMH**



Tube facing milling head created for facing any type of material tubes. Utilizes 6% cobalt inserts.

TABLE FOR TFMH, PAGE 37

**TFMHL LONG REACH FACING HEAD**



Long reach facing head, designed to trim back tubes that are positioned very close to the shell or channels of heat exchangers.

TABLE FOR TFMHL LONG REACH, PAGE 38

**EXAMPLE TOOL APPLICATION**

